

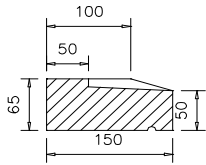

# Cills

2.0



**TYPE 1 CILL  
TYPICAL SECTION**

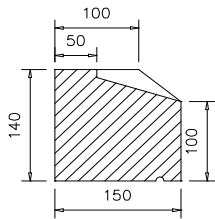

**TYPE 2 CILL  
TYPICAL SECTION**

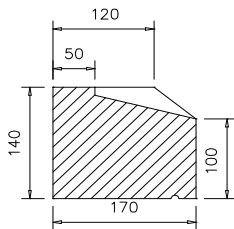

**TYPE 3 CILL  
TYPICAL SECTION**

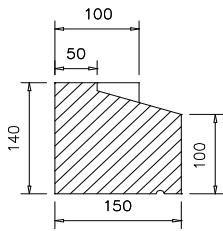

**TYPE 4 CILL  
TYPICAL SECTION**

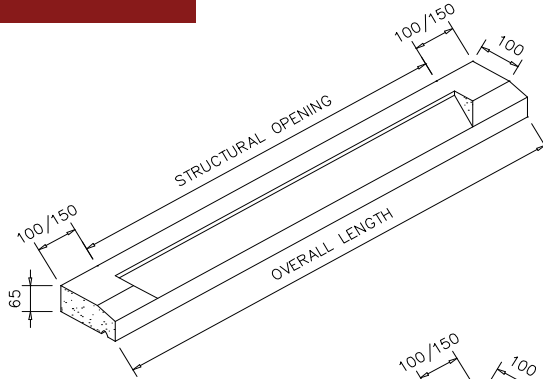

**TYPE 1  
APPROX 22KG PER LM**

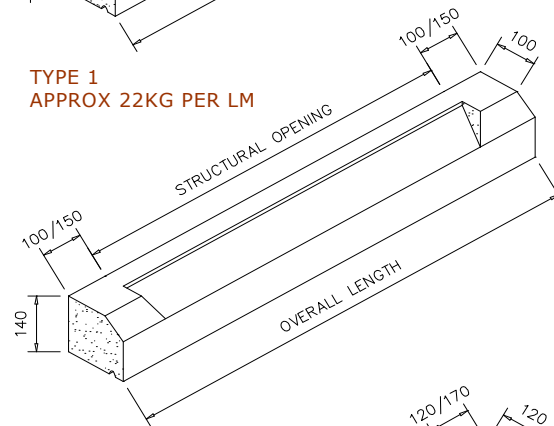

**TYPE 2  
APPROX 48KG PER LM**

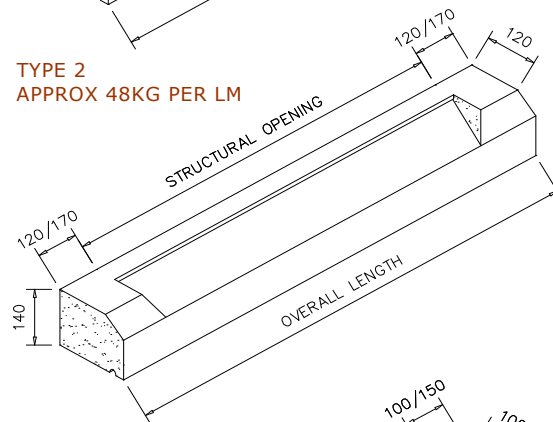

**TYPE 3  
APPROX 55KG PER LM**

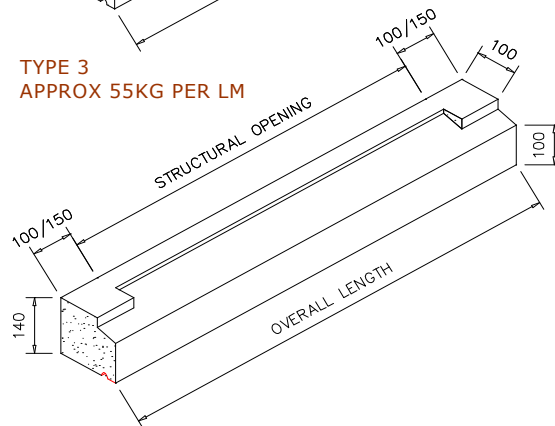

**TYPE 4  
APPROX 48KG PER LM**

**NOTE:**

ALL TYPE 1 CILLS OVER 890MM LONG WILL BE SUPPLIED SECTIONAL, UNLESS PREVIOUSLY AGREED

ALL TYPE 2, 3 AND 4 CILLS OVER 1400MM LONG WILL BE SUPPLIED SECTIONAL, UNLESS PREVIOUSLY AGREED

STANDARD STRUCTURAL OPENING SIZES INCLUDE 488MM, 630MM, 915MM, 1200MM, 1770MM

NON-STANDARD LENGTHS AND SECTIONS MANUFACTURED TO ORDER

ALL CILLS AVAILABLE-DELETE STOOLS TO FORM SLIP CILLS

10MM RAINWATER DRIP LOCATED TO FRONT UNDERSIDE OF ALL PROJECTING CILLS

TYPE 3 CILL RECOMMENDED FOR RENDERED BRICKWORK FINISHES